

### The Benefits of Steam Tracing vs. Electric Tracing

Written by Horst Thieme, PE, James R. Risko  
and the Fluid Controls Institute Steam Trap Section

Many articles have been written concerning the advantages of steam over electricity (or vice versa) for tracing applications. A valid case can probably be made for either, depending on the method being promoted by the particular author. These promotional articles have generally been based on strictly economical considerations which represent only part of the story. This article is intended to provide insights into inherent practical advantages of steam which may have been overlooked in the past. Here are some points and simplified piping schematics to consider.

#### Trace Heating

Trace heating is a vital element in the reliable operation of pipe lines, storage and process vessels throughout the process industry. Anti-frost protection for water pipelines is needed both in the processing industries as well as in commercial and domestic buildings. Of equal importance is the tracing of process pipelines which carry liquids that can be pumped only at temperatures that are well above the freezing temperature of water. For example, many oil and fat lines have to be heat traced. In the chemical process industry a multitude of products such as asphalt and sulfur can only be moved through pipe lines at specific temperatures.

#### Which tracing method

The amount of heat energy required to maintain the desired temperatures may influence the type of tracing to be used. (The heat load calculation methods are beyond the scope of this discussion). The choice of tracing method will usually lie between **steam, hot liquid or electrical tracing**. Hot water is often used in the food industry where relatively low temperatures are desirable, such as keeping chocolate in a molten state, and hot oils are sometimes used in chemical processing especially when high temperatures are required. For the majority of applications, however, the choice falls between steam tracing and electrical tracing.

#### Electrical tracing

For short runs of water pipes, and where no supply of steam is readily available, electrical tracing may be a preferred alternative. In some cases, electrical tracing may be applicable on longer runs provided that the anticipated protection is just above the freezing point of water, where the heat loads will be quite small.

#### Steam tracing

For extensive pipe runs as found in most of the industrial process field, steam tracing has long been accepted as the preferred method for maintaining appropriate pipe line or product temperatures. In most cases the steam is supplied at low pressures and is transmitted to pipe lines, valves, and pumps through stainless or copper tubing. This tubing ranges in size from 1/4"- 1/2" diameter for winterization or instrumentation tracing, and 3/8" to 1" diameter for process pipe tracing. (Figure 1). In some instances, extremely high heat flow is required, and this can only be accomplished with the use of jacketed piping. (Figure 2). In all cases, condensate produced in the tracers is easily removed at strategic locations using modern, compact, and highly energy efficient steam traps. The condensate can then be returned to the boiler to achieve even further savings in energy, water, and water treatment.

### Temperature Control

Tracing applications require some form of temperature control. Due to the pressure/temperature relationship of saturated steam, temperature control is easily achieved through steam traps, pressure regulators, and temperature regulators. Subcooling thermostatic traps are generally used in non-critical, low temperature applications as an inexpensive means of rudimentary temperature control of the discharged condensate. (Figure 3). Pressure or temperature regulators are used in applications which have more critical implications (typically high temperature) and where close temperature control is essential.

Temperature regulators are really pressure regulating valves that control temperature by modulating steam pressure. Simple temperature control can easily be achieved with self-contained pressure regulators (Figure 4), or where product temperature control is needed, with adjustable temperature regulators (Figure 5). These temperature regulators consist of a thermal bulb which operates a control valve, and they **require no external power** source. This provides control combined with excellent reliability and safety. For winterization, simple ambient temperature sensing valves can also be used to turn the steam on and off automatically (Figure 6).

With electric heating, temperature control is somewhat more difficult to obtain. For non-critical applications, constant-resistance type tracers, in conjunction with locally mounted on-off type thermostats are commonly employed, which can provide cyclic control with temperature fluctuations. If the application requires more precise regulation, it can only be achieved through modulating control, which requires more sophisticated methods such as “Pulse Width Modulation” to regulate the power output.

One of the more difficult applications that may require such precise control is electric heat tracing of instrument enclosures. Simple steam tube tracing supply to a subcooling thermostatic trap will often meet the enclosure needs in the most effective and reliable manner. (Figure 7). Close temperature control, when needed, can be accomplished using a self-contained temperature regulator on the steam line.

### Explosion Proofing

Many facilities, especially refineries and chemical plants, operate under flammable or explosive atmospheric conditions. Under these circumstances, all equipment must meet strict explosion proof requirements so that the devices cannot cause a fire or an explosion. The degree of explosion proof requirement is broken down into classes and groups that depend on the location and type of explosive or flammable medium present. With the advent of low power solid state electronic devices, **intrinsic safety** may be an important issue concerning an installation. According to the Instrument Society of America (ISA), intrinsically safe equipment is defined as “equipment and wiring which is incapable of releasing sufficient electrical or thermal energy under normal or abnormal conditions to cause ignition of a specific hazardous atmospheric mixture in its most easily ignited concentration.” (ANSI/ISA-RP12.6). It stands to reason that intrinsically safe circuits (devices) are most desirable. This requires extensive special considerations such as explosion proof junction boxes, armored wiring, or other current-limiting components, etc. to protect the circuit from external damage. **This could represent a costly installation requirement that may not be practical.**

## Tech Sheet #ST 102

Now consider steam for the same heating application. By comparing it to the ISA definition of intrinsic safety, **steam is intrinsically safe!** This fact alone should in many cases be the deciding factor for choosing steam tracing over electrical tracing.

### Making the Choice

The foregoing discussion points out just some specific advantages of steam tracing systems versus electrical tracing systems. The final choice rests with the user or system designer. It is hoped that the final user will make an independent analysis of the application's requirements and select the tracing method with characteristics most suitable to provide safe and reliable trace heating.

Mr. Thieme\* and Mr. Risko participate as members of the Fluid Controls Institute (FCI) Steam Trap Section. The Fluid Controls Institute (FCI) is a non-profit trade association dedicated to the technical advancement and increased understanding of the fluid control, handling, and measurement equipment. The FCI traces its origins to 1921 and has been known as the Fluid Controls Institute since 1955.

FCI standards and publications are designed to aid in the proper selection, application, and operation of fluid control, handling, and measurement equipment.

While the recommendations for trace heating contained herein are technically sound, it is not intended that they be considered the only method for trace heating. These recommendations should not be interpreted as superior to or a standard that would necessarily be preferred in lieu of an engineer's design for a particular system.

These recommendations for trace heating originate from the collective experience of leading personnel in the fluid control industry, but must, due to the nature of the responsibilities involved, be presented only as a guide for the use of a qualified designer or engineer. Thus, the Fluid Controls Institute, Inc. expressly disclaims any responsibility for damages arising from the use, application or reliance on the recommendations and information contained herein by designers or by engineers.

\*Published posthumously

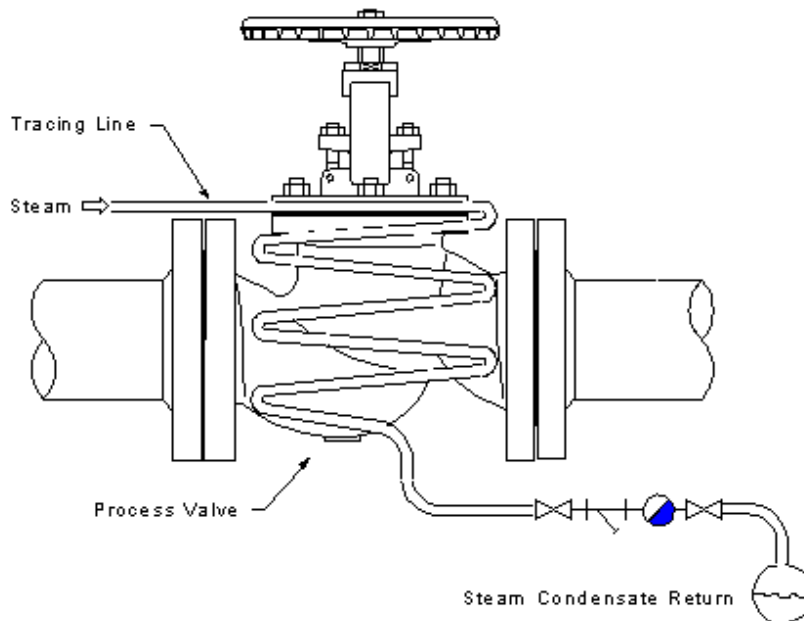
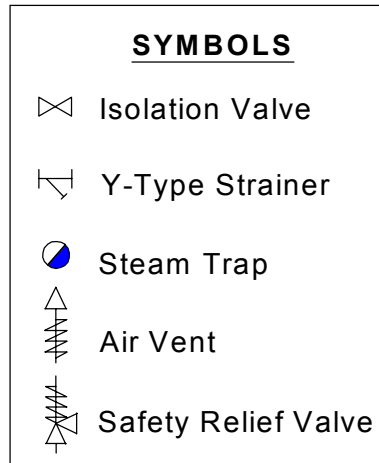
The following companies are members of the FCI Steam Trap Section:

Armstrong International, Inc.  
 Bestobell Steam  
 ITT Domestic  
 MEPCO  
 Nicholson Steam Trap

Spirax Sarco, Inc.  
 TLV CORPORATION  
 Tunstall Associates, Inc.  
 Watson McDaniel Company

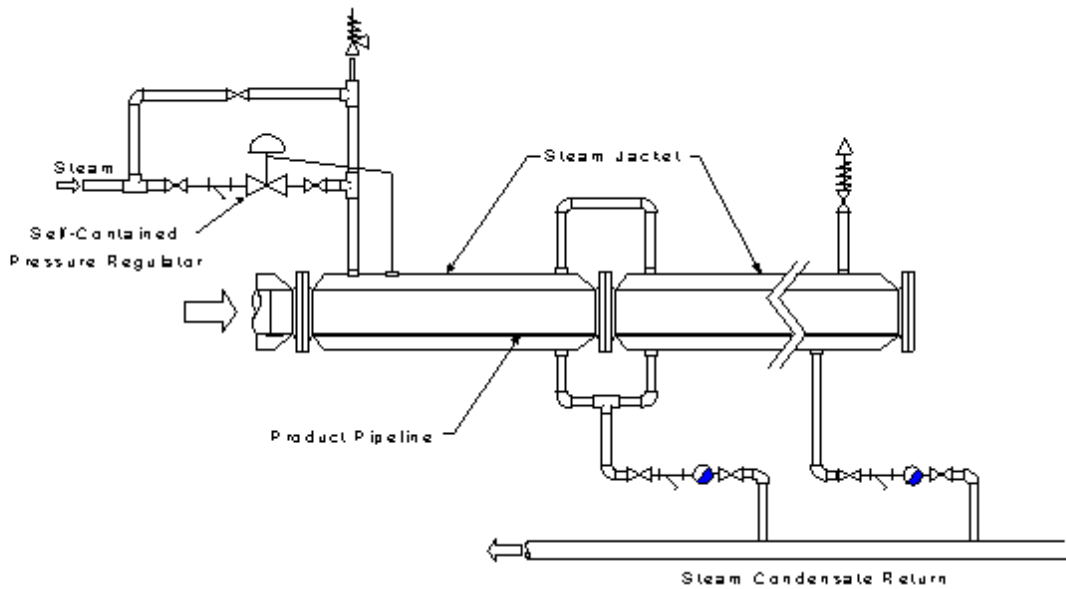
This Tech Sheet was developed by the members of the Fluid Controls Institute (FCI) Steam Trap Section. FCI is a trade association comprising the leading manufacturers of fluid control and conditioning equipment. FCI Tech Sheets are information tools and should not be used as substitutes for instructions from individual manufacturers. Always consult with individual manufacturers for specific instructions regarding their equipment.

**Figures**

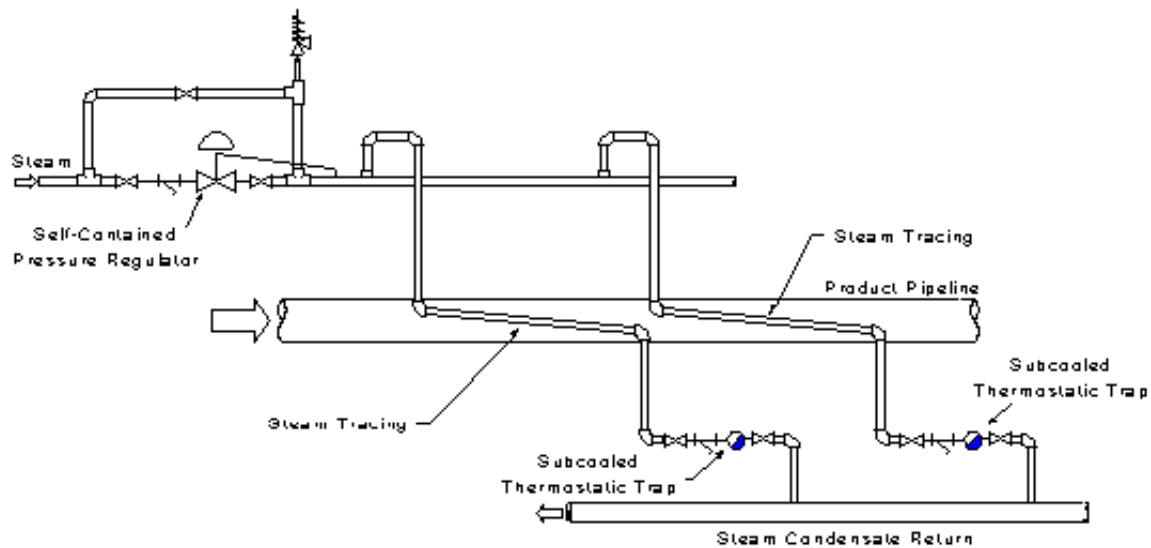


**Figure 1**

This Tech Sheet was developed by the members of the Fluid Controls Institute (FCI) Steam Trap Section. FCI is a trade association comprising the leading manufacturers of fluid control and conditioning equipment. FCI Tech Sheets are information tools and should not be used as substitutes for instructions from individual manufacturers. Always consult with individual manufacturers for specific instructions regarding their equipment.



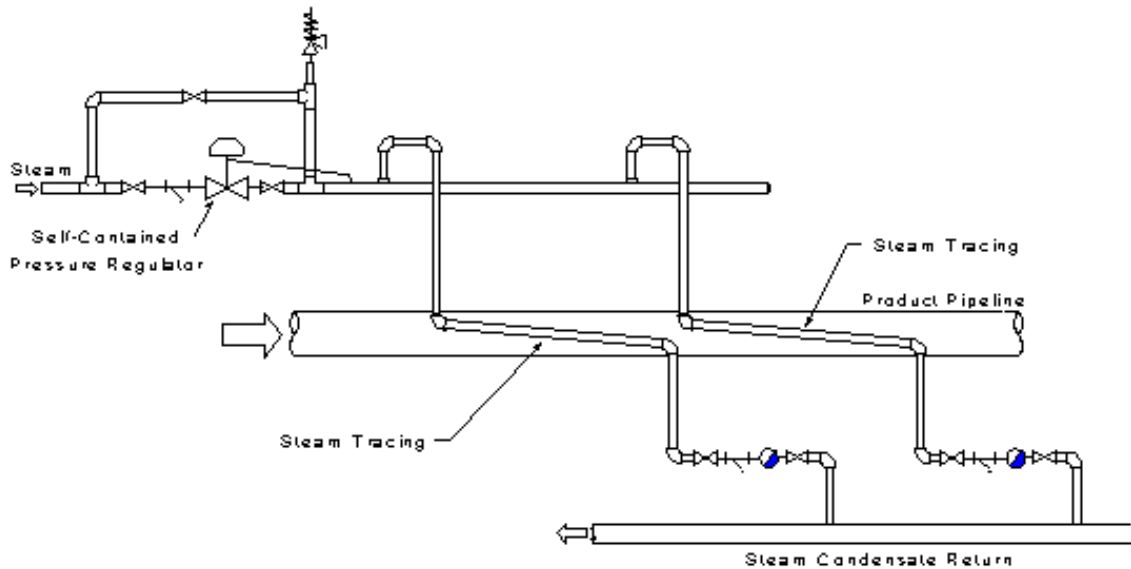
**Figure 2**



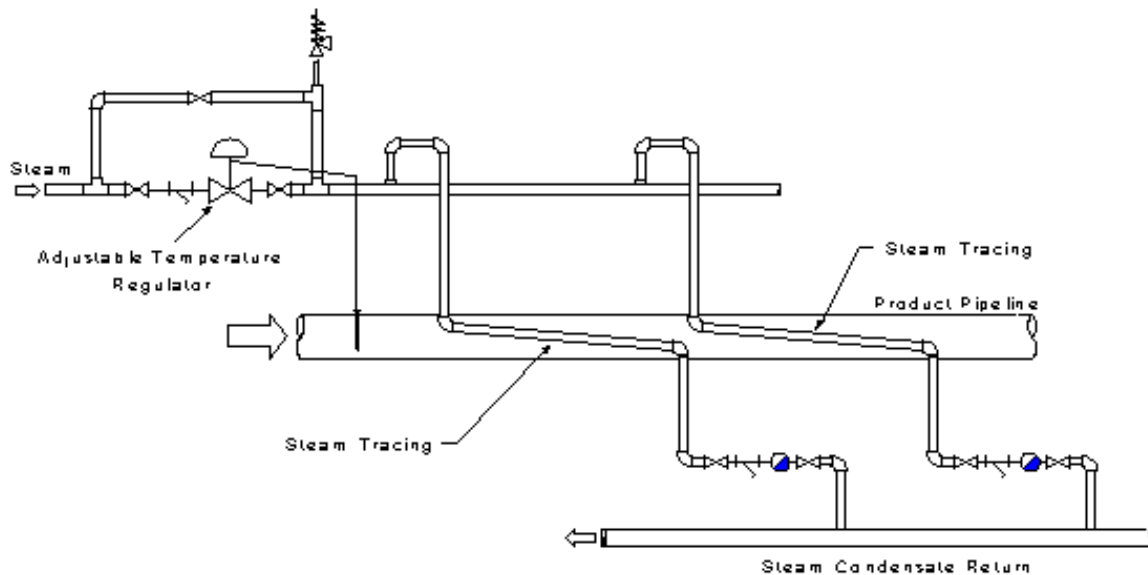
**Figure 3**

This Tech Sheet was developed by the members of the Fluid Controls Institute (FCI) Steam Trap Section. FCI is a trade association comprising the leading manufacturers of fluid control and conditioning equipment. FCI Tech Sheets are information tools and should not be used as substitutes for instructions from individual manufacturers. Always consult with individual manufacturers for specific instructions regarding their equipment.

**Tech Sheet #ST 102**

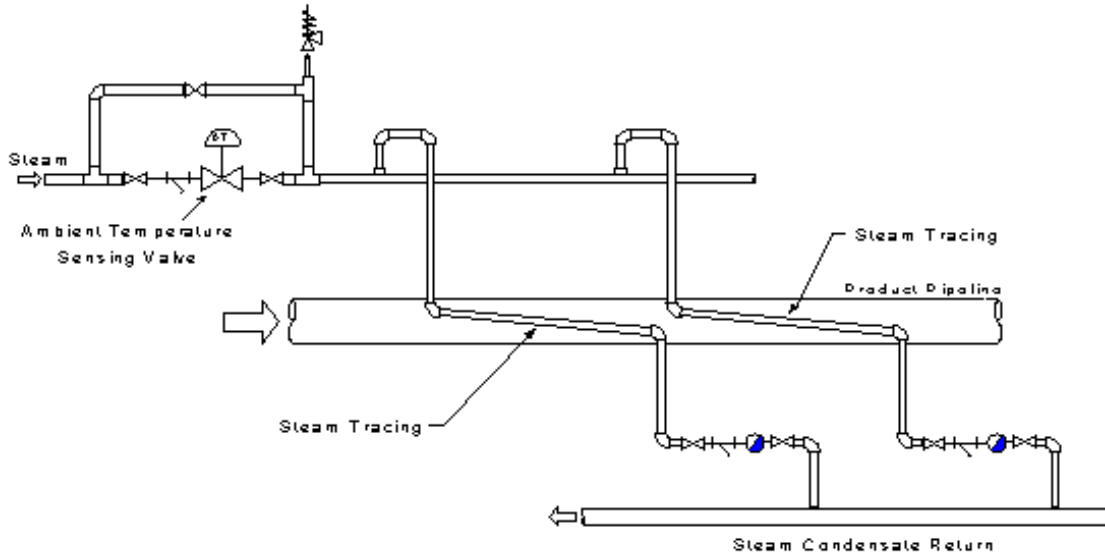


**Figure 4**

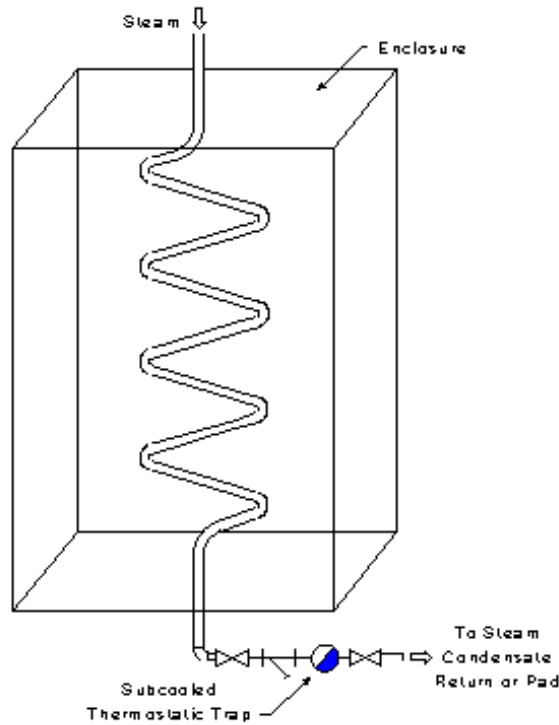


**Figure 5**

This Tech Sheet was developed by the members of the Fluid Controls Institute (FCI) Steam Trap Section. FCI is a trade association comprising the leading manufacturers of fluid control and conditioning equipment. FCI Tech Sheets are information tools and should not be used as substitutes for instructions from individual manufacturers. Always consult with individual manufacturers for specific instructions regarding their equipment.



**Figure 6**



**Figure 7**

This Tech Sheet was developed by the members of the Fluid Controls Institute (FCI) Steam Trap Section. FCI is a trade association comprising the leading manufacturers of fluid control and conditioning equipment. FCI Tech Sheets are information tools and should not be used as substitutes for instructions from individual manufacturers. Always consult with individual manufacturers for specific instructions regarding their equipment.