



# Engineering Specification for the Selection, Installation and Maintenance of Pipeline Strainers

*Prepared by*  
PIPELINE STRAINER SECTION  
FLUID CONTROLS INSTITUTE, INC.

## **CONTENTS**

- 1 – Pipeline Strainers – Definition, Purposes and Types
- 2 – End Connections
- 3 – Materials of Construction
- 4 – Corrosion Resistance – Selection of Materials
- 5 – Perforations and Mesh Sizing
- 6 – Capacity
- 7 – Pressure Loss
- 8 – Specifications and Manufacturer Testing
- 9 – Shock – Hydraulic and Thermal
- 10 – Conclusion

## **PREFACE**

Experience has proven the need for strainers in the protection of pumps, compressors, turbines, meters, automatic valves, sprinkler heads, burner nozzles, steam traps and other pipeline equipment.

This guide has been established as a technical reference for project engineers and managers responsible for specifying and using pipeline strainers. While strainers remain a relatively low cost item, when specified properly, the protection they provide is invaluable. It is the intent of this guide to provide the background and information necessary to make knowledgeable and sound engineering decisions in the specification of pipeline strainers.

The Pipeline Strainer Section of the Fluid Controls Institute, Inc. acknowledges and appreciates the assistance of those people who have made the creation and updating of this technical resource possible.

## **CHAPTER 1**

### ***Definition***

A pipeline strainer is a device which provides a means of mechanically removing solids from a flowing fluid. This is accomplished by utilizing a perforated metal, mesh or wedge wire straining element. The most common range of strainer particle retention is 1” to 40 micron (0.0016”).

### ***Purpose***

Strainers are employed in pipelines to protect downstream mechanical equipment such as condensers, heat exchangers, pumps, compressors, meters, spray nozzles, turbines, and steam traps from the detrimental effect of sediment, rust, pipe scale, or other extraneous debris.

### ***Types of Strainers***

Specified strainers are the Y strainer and the basket strainer. While there is primarily one type of Y strainer (Fig. 1A), there are several variations of basket strainers (Figs. 1B through 1D).



**Figure 1A**



**Figure 1B**



**Figure 1C**

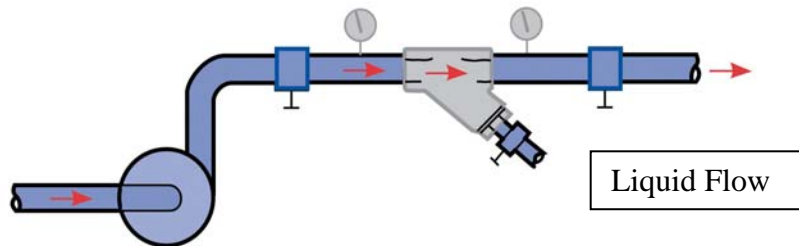

**Figure 1D**

### ***Y Strainer, Basket Strainer***

Vertical piping, frequently found at pump inlets, necessitates the use of a Y strainer or a tee type basket strainer. Most basket strainers are intended for horizontal or slightly inclined piping. Special attention must be given to the orientation of the debris collection chamber and the drain (blowdown) connection of the strainer. The strainer must be installed such that

it is located at the lowest possible position (Fig. 2). For liquid flow a Y strainer in vertical piping must be placed with its screen in the downward position to trap the sediment in the debris collection chamber. For steam service, it is recommended that Y strainers be mounted sideways in horizontal lines to prevent condensate accumulation.



**Figure 2**

Tee type strainers, suction diffusers and several variations of basket strainers can also be used in a right angle flow application (Fig. 3).

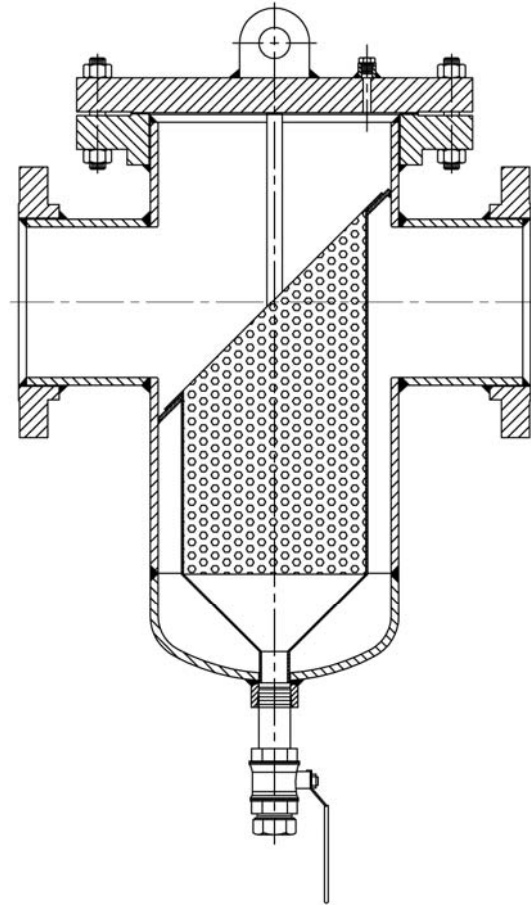

**Figure 3**

Y strainers and most variations of basket strainers can be self-cleaning. With the addition of a blowdown valve and some modification of the straining element of a basket strainer, the element can be flushed out by opening and closing the blowdown valve. This can be accomplished without flow stoppage or disassembling any piping.

In sizes above 4", a single basket strainer will generally create less pressure drop than a Y strainer. Basket strainers are normally installed in a horizontal pipeline with the cover over the basket at the top. Cleaning of the strainer is generally simple and no draining is required. Cover flanges for basket strainers are relatively easy to remove and servicing is simple. Replacement of covers is facilitated by some manufacturers through the use of studs, rather than bolts, which help to align the cover during the replacement operations. Hinged covers and screen locking devices can also make servicing easier.

There seems to be a general misconception among engineers and contractors concerning Y strainers and basket strainers used in steam service. In many instances, basket and Y strainers will perform comparably in steam service. It is essential in ordering strainers for steam service that the manufacturer be so advised. As mentioned above, the housings may be furnished with a special bottom, allowing the accumulated debris to be blown out by opening the blowdown valve (Fig. 4).



**Figure 4**

While there are some high pressure applications for basket strainers, (Fig. 5), due to the required thickness and subsequent high cost, basket strainers are not normally constructed for pressures above 1 500 psi. Y strainers, on the other hand, are readily available for working pressures of 6 000 psi and higher. In addition to Y and basket types, other strainers are

available such as duplex/twin, temporary/geometric, washdown/back-flushing, automatic self cleaning, plate or expanded cross section type, and scraper types. Descriptions of these as well as miscellaneous options available with them follow.

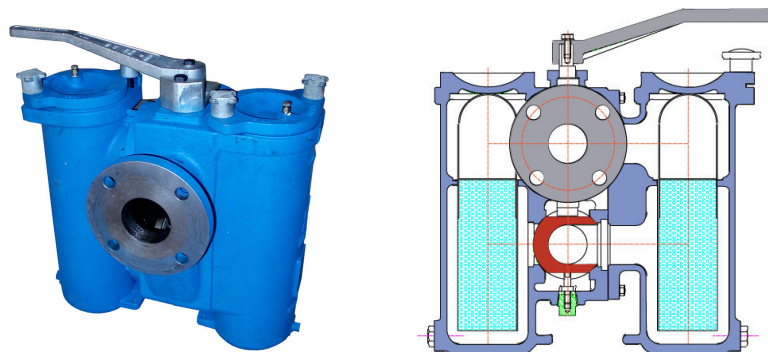

**Figure 5**

### ***Duplex/Twin Strainers***

For applications where continuous operation is required and the line cannot be shutdown for cleanout, duplex or twin (dual) basket strainers can be used. Refer also to Automatic Strainers for continuous service applications. Examples are fuel oil strainers for industrial or marine oil burners, lubricating lines on ships, cooling towers, continuously running chemical operations, and many industrial water intake and service lines.

When one basket becomes full, the flow is switched to the other basket. The first basket is removed, cleaned and replaced. For smaller sizes the plug-type or ball-type duplex basket strainer (Fig. 6) is generally used since it is less costly to construct, and simpler to operate and maintain than other types. It is basically two connected valves with two integral basket wells into which flow can be diverted by rotating the handle.



**Figure 6**

Twin (dual) basket strainers, two single basket strainers connected in parallel with individual control valves, are also available (Fig. 7). It occupies more space than a duplex strainer. However, because of the more circuitous path the liquid must take through a duplex strainer, pressure drop is higher than through the equivalent size single or twin basket strainer.



**Figure 7**

### ***Temporary (Geometric) Strainers***

Where cost is of prime importance, a temporary strainer may be installed between flanges in a pipeline. Variations of temporary strainers include cone (Fig. 8A), truncated cone (Fig. 8B) and flat (Fig. 8C) geometries. The design considerations with these types of strainers are:

1. They have a lower net open area than basket strainers.
2. The pipeline must be disassembled to inspect, clean or remove these strainers.
3. Structural strength can be difficult to achieve, particularly in larger sizes, and in the case of wire mesh.



**Figure 8A**



**Figure 8B**

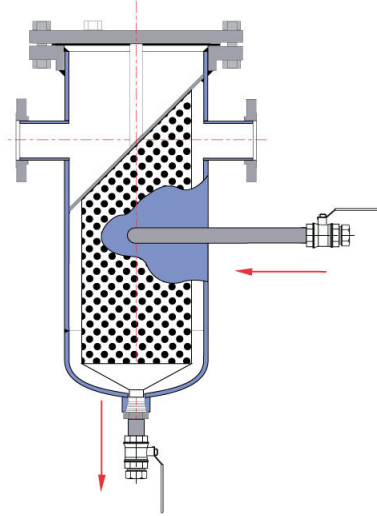

**Figure 8C**

While these strainers were once used only temporarily or for startup, frequently they are now left in the line during operation. As with all types of strainers, periodic maintenance must be carried out to ensure efficient operation.

### ***Washdown, Manual, Fixed or Rotary Spray, Back-Flushing Strainers***

These strainers are fitted with side inlets or other devices for the introduction of high velocity liquid (the same as being strained – usually water). The velocity of the water and the turbulence created back-flush the strainer basket and opening a drain valve evacuates the debris (Fig. 9).



**Figure 9**

### ***Automatic Self-Cleaning Strainers***

An automatic self-cleaning strainer is a unit which goes through a complete cleaning cycle, using some of the fluid flowing through the strainer to flush out the collected debris, with little or no attention by the plant personnel. There are numerous styles of automatic strainers produced and each has its desirable features; however, only a limited discussion is presented in this article.

Figure 10 is an example of basic types of automatic self-cleaning strainers. Automatic strainers are normally more expensive than the manually cleaned units but their extra cost can often be justified by one or more of the following reasons:

1. The frequency of cleaning of a manual unit and the cost of labor for doing this.
2. If there is any danger that the strainer or the equipment that it is protecting may be damaged by the strainer not being cleaned when required.
3. The strainer is necessarily located in a place where it is not readily accessible for cleaning.
4. Plugging of the strainer is unpredictable due to a variable loading rate such that manual cleaning cannot be properly scheduled.
5. Insufficient available personnel to perform the manual cleaning.

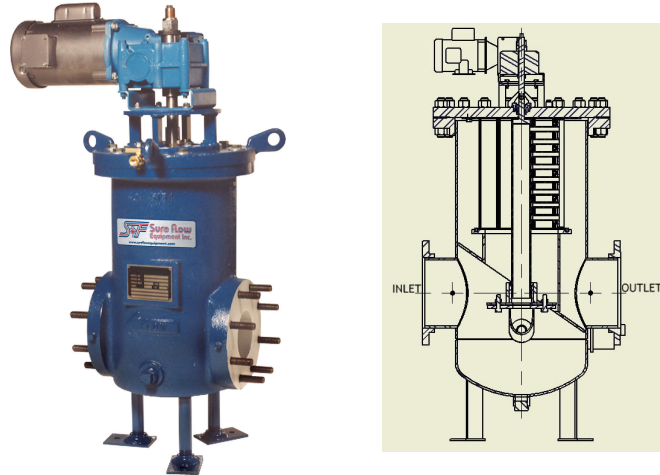

**Figure 10**

There are many types of automatic and semi-automatic controls for the strainer. Among these are:

1. Differential pressure switch which senses the pressure drop across the strainer and initiates a cleaning cycle at a preset pressure differential.
2. Timer which initiates cleaning cycle of strainer at preset intervals of time.
3. Pushbutton start for which an operator pushes a button to initiate a cleaning cycle (semi-automatic).
4. Differential pressure switch alarms which signal the operator that the strainer needs cleaning (semi-automatic).
5. Any combination of the above controls.

All of the above control systems are normally used with strainers that clean intermittently. Some automatic strainers also clean continuously so that a control to initiate the cleaning cycle is not required.

For intermittent cleaning strainers, the differential pressure switch control is normally preferred, because it will initiate a cleaning cycle when required regardless of strainer plugging rate. If a fairly constant strainer plugging rate occurs, the timer control can be utilized. Also, if the strainer may go through long periods of slow plugging during which it may not clean, a timer control may be desired to make certain the strainer operates periodically to keep it from binding. Because of its automatic self-cleaning characteristics, an automatic strainer is normally cleaner for longer periods of time than an equivalent manually cleaned strainer.

When used in process or plant service water systems, it is not normally necessary to prescreen the liquids handled by self-cleaning strainers. It is essential, however, that any self-cleaning strainer be protected from logs, long sticks, and heavy concentrations of large fish when the strainer is installed in intake systems where water is being taken from a river, lake or other surface water source. When very fine process straining is desired, two self-cleaning strainers in series – one coarse and one fine – should be considered.

Automatic strainers are most commonly used on water service, the primary reason being the difficulty of disposing of the fluid which flushes the debris from the strainer. However, most automatic strainers can work on other fluids if the fluid can be disposed of satisfactorily. Many successful applications have been made with such fluids as black liquor, white water, starch, fuel oils (including Bunker C), lubricating oils, machine coolants, gasoline, ammonia flushing liquor, caustic solutions, and cooking oils.

***Plate or Expanded Cross Section Strainers***

Where short face-to-face dimensions are essential, the plate strainer may be used (Fig. 11). A temporary strainer is also an option. Only low net open areas are available with this type of strainer. In addition, operating pressure drops are normally higher and maximum allowable pressure drops lower than with other types of strainers.

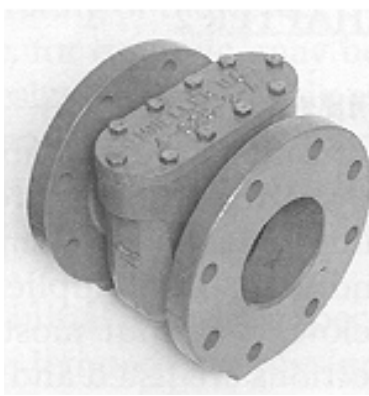

**Figure 11**

For applications where continuous operation is required, a scraper strainer provides removal of solids without interrupting flow (Fig. 12). Disassembly of the strainer is not required for cleaning. Examples are straining of industrial cooling water (chemical, petroleum, power, and steel), cooling towers, water intake, marine systems, industrial and marine fuel filtration, and deluge fire protection systems. Screens are of the peripheral inflow design. Rotation of hand wheel rotates the screen against a scraper bar or brush removing collected debris from the screen's outer surface. Debris moves to the sump area where it is removed by periodic flushing. Scraper strainers can normally be converted from manual to automatic self-cleaning operation.



**Figure 12**

### ***Special Application Strainers***

#### ***A. High Differential Strainers***

There is an increasing demand for strainers with screens which can withstand full line pressure when clogged. While the types of strainers already discussed can be structurally enhanced to withstand fairly high pressures (Fig. 13A and 13B), cases where extremely high differentials exist may call for special design. These screens are frequently constructed of very heavy wire mesh or welded to ensure complete structural integrity. A few manufacturers can supply these strainers over a wide range of pressure requirements.



**Figure 13A**

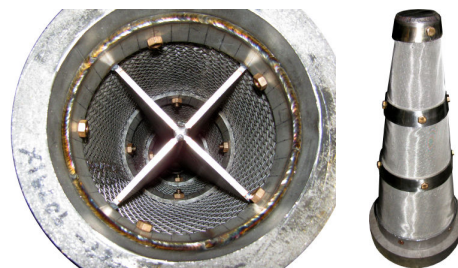

**Figure 13B**

#### ***B. Micronic Strainers***

Strainers are available with extremely fine wire mesh which will remove particles as fine as five microns. These strainers, though expensive, are more economical than the disposable cartridge-type filters because the straining elements can be cleaned and reused. Corrosion resistance is also better in most cases. Baskets must be supplied with a gasket, o-ring, or close tolerance metal-to-metal seal to eliminate bypass. Oil separation can be accomplished with cotton or fiber-filled screens. Water can be separated from gasoline using a fine mesh. Bronze or stainless steel wool-packed straining elements also serve certain filter requirements.

### ***C. High Capacity (Volume) Basket Strainers***

High capacity strainers are designed for viscous fluids, gasoline, and fuel oil service where fine straining has to be combined with a large basket which will not clog for extended periods. A gasketed seat or close tolerance metal-to-metal fit for the baskets ensures that no bypassing of fine particles will occur.

### ***D. Magnetic Strainers***

An effective solution to the problem of excessive and premature wear of pump seals and wear rings is a magnetic screen assembly. A standard strainer is fitted with magnets which are removable for cleaning (Fig. 14). These magnets are so spaced and arranged as to create a magnetic field around the interior of the screen and attract fine ferrous particle which could damage downstream equipment (Fig. 17).

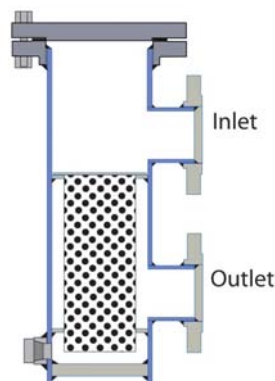

**Figure 14**

Engineers have specified this type of strainer in pilot jobs and, after evaluation, have standardized this specification for all pump strainers. Magnets can be incorporated in almost any of the Y, basket or temporary type strainers.

### ***E. Offset***

In some cases a strainer is required at the inlet of a pump or meter which is extremely close to the ground. An offset strainer (Fig. 15) with a high inlet and low outlet will satisfy this need. Other designs may use a tee type basket strainer (Fig. 3) in an angle flow application.



**Figure 15**

### ***F. Reducing***

Quite frequently line sizes are reduced following a strainer prior to temperature control valves or heating and cooling coils (Fig. 16). A reducing strainer can eliminate joints, reduce pressure loss, and still provide the same offset produced by the reducer. Of course, the reducer is also eliminated.

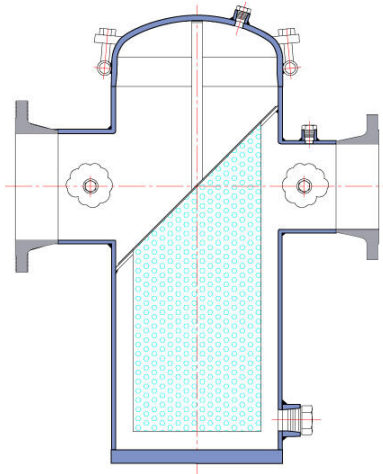

**Figure 16**

### ***G. Jacketed***

Special processes may warrant special strainer housings. Steel or stainless steel strainers may be fitted with a fabricated or cast outer jacket with connections for the introduction of steam or other heating or cooling medium (Fig. 17). These types of strainers are used mainly in process piping applications where the liquid handled must be maintained at above ambient temperatures.

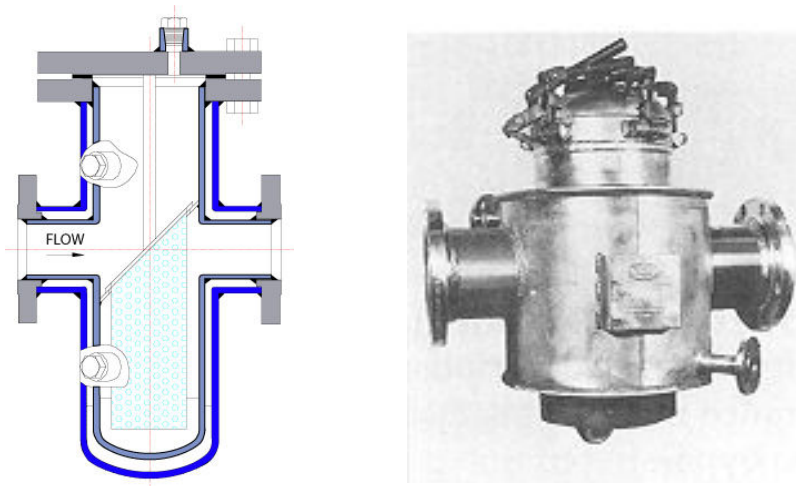

**Figure 17**

In addition to special process needs, there may be special maintenance needs. Simplifying the handling of strainers during cleanings or inspections reduces maintenance costs. Strainers are available with many types of quick-opening covers to reduce the length of time and labor involved in cleaning operations (Fig. 18). Among these are swing eye bolts, yoke covers, pinwheel covers and “C” washers. The variety of closures are too numerous to mention, but consideration should be given to them where reduction of downtime is important. Additionally, many of these closures can be operated without the use of tools, which enables workers to service the strainer where union contracts require only maintenance personnel to use tools.



**Figure 18**

## **CHAPTER 2**

### ***End Connections***

Strainers are available in a variety of end connections. The four most common types of end connections are discussed below. Iron strainers are most commonly furnished in either threaded or flanged ends. Steel, stainless steel and bronze strainers are readily available with any of these end connections.

#### ***A. Threaded***

Usually a tapered female pipe thread, although male connections are also available.

#### ***B. Flanged***

ASME (American Society of Mechanical Engineers) and MSS (Manufacturer's Standardization Society) standard flange rating Classes 25, 125, 150, 250, 300, 400, 600, 900, 1500 and 2500 can be supplied. Ring type joints (male and female), and tongue and groove joints are also available. The U.S. Navy also has some flange standards which are quite different from the commercial standards. Among these are B-176, B177, and MIL-F-20042C.

### ***C. Weld Ends***

Butt weld end strainers are generally available in all sizes, and although many forms of end preparations can be used, the standard 37.5° beveled end is most common. ASME B16.25 illustrates the various types of weld joint preparations available. It is very important that the purchaser specify the bore of pipe being used so that the manufacturer can provide a matching bore in the strainer. Butt weld strainers are difficult to hydrostatically test before being welded in place in the field.

Socket weld end strainers are usually available in sizes through 3". In ordering weld end strainers of any type, consider whether you desire a welded blowdown connection.

### ***D. Special Ends***

Grooved ends are available on many strainers, and a detail of this end should be supplied to the manufacturer. Other special ends such as o-ring and union ends are also available on special order, and complete details should be furnished.

Most Y and certain other types of small strainers are designed according to the fitting standards for full pressure ratings and therefore can be subjected to higher working pressures at lower temperatures. It should be clearly understood; however, that most of the larger types and many of the smaller strainers are designed for the working pressure requested and should not be operated above that pressure without consulting the manufacturer. It is important to note that the flange rating is not necessarily the same as the pressure rating of the vessel. A fabricated carbon steel strainer, for example, may be operated at 40 psig at 500 °F, designed for 100 psig at 650 °F, and have ASME Class 150 flanges. The maximum safe pressure at any temperature (650 °F and below) for this vessel is 100 psig, even though the flange is rated for 170 psig at 500 °F.

It is important, at the time of initial design, to specify working pressure, working temperature, design pressure, design temperature, any corrosion allowance, required flange rating and any operating conditions affecting vessel loading.

## **CHAPTER 3**

### ***Materials of Construction***

Strainer components can include a body, flanges, cover, perforated plate, mesh, wedge wire, gasket and cover fasteners. Listed below are some materials of construction for these components.

## ***Housing/Body***

<b>Description</b>	<b>ASTM Specification</b>
Iron Castings	A126, A278
Ductile Iron Castings	A395, A536
Iron-Austenitic Castings	A436
Carbon Steel Castings	A216, A27
Carbon Steel Pipe	A53, A106
Carbon Steel Plate	A20, A285, A515, A516
Carbon Steel Forgings	A105
Carbon Moly Castings	A217, A352
Chrome Moly Forgings	A182
Stainless Steel Castings	A743, A744, A351
Chrome Moly Plate	A387
Chrome Moly Pipe	A335
Stainless Steel Pipe	A312
Stainless Steel Plate	A240
Stainless Steel Forgings	A182
Aluminum Castings	B26
Bronze Castings	B61, B62
Monel	B164, B127
Nickel 200 Plate	B160, B162
Hastelloy B Castings	A494
Hastelloy B Plate	B333
Hastelloy C Plate	B575
Hastelloy C Pipe	B619
Titanium Pipe	B337
Titanium Castings	B367

## ***Perforated Plate/Mesh/Wedge Wire***

Carbon Steel	Stainless Steel (Various Grades Available)
Monel	Hastelloy B
Hastelloy C	Alloy 20
Nickel	Brass
Copper	Galvanized Steel
Incoloy	Inconel
Titanium	Aluminum

## ***Gaskets***

Red Rubber	Compressed Nonasbestos Fiber
Teflon	Buna-N O-ring
Neoprene	Stainless Steel – Jacketed
Graphite	Stainless Steel – Spiral Wound
Viton	

### ***Fasteners***

Carbon Steel	Alloy Steel
Silicon Bronze	304 Stainless Steel
316 Stainless Steel	Monel

## **CHAPTER 4**

### ***Corrosion Resistance – Selection of Materials***

Almost every strainer operating in a pipeline is subject to some degree of corrosion or erosion. It is therefore very important that corrosion/erosion resistance is considered when selecting materials and/or coatings. The selection of the material or coating used is usually also based on economic considerations. This decision should be made by the customer and/or consulting engineer after some discussion with the strainer manufacturer.

It is important that the type of fluid, the pressure and temperature conditions, type of adjacent piping, desired service life, and the customer's prior experience with similar fluid conditions be known. Corrosion resistance charts offer some assistance in the selection of materials or coatings. (See Corrosion Data Survey – Metals Solution, 6<sup>th</sup> Edition, NACE, etc).

Electrolytic corrosion is also a consideration in some services and the manufacturer should be advised. Sometimes the inclusion of magnesium or zinc consumable bars in the body will retard this action.

Most types of strainers can be lined with various coatings to retard corrosion. Some of these are listed below:

Epoxy	Asphalt
Teflon	Vinyl
Kel-F	Rubber
Neoprene	Baked Phenolic
Penton (Plating: Zinc, Cadmium, Nickel, Galvanizing, etc.)	

## **CHAPTER 5**

### ***Perforations and Mesh Sizing***

An extremely important consideration in the selection of a strainer is the size of the perforations, mesh or wire opening used in the fabrication of the straining element. A tendency exists to select smaller holes than those actually needed, leading to too-frequent cleaning, excessive pressure drop, and screens constructed of thinner metal which will withstand less pressure differential.

Generally, the maximum thickness of stainless steel perforated metal is one gage thickness less than the diameter of the punched holes. Carbon steel and brass can be obtained in approximately the same thickness as the punched hole diameter. These limitations are

important considerations. For example, a strainer made with stainless steel plate perforated with 1/64" diameter holes in a 16" line would be impractical. The plate would be approximately 17" in diameter and only 0.014" thick, and would have a very low maximum allowable differential pressure.

The most common way to accomplish fine straining in large strainers is by mesh lining a heavier gage perforated plate with larger holes.

The following tables illustrate available perforated plate, mesh, and wedge wire and their respective straining capability. The main criteria for choosing hole and mesh size is the size and quantity of particles which can pass through downstream equipment without causing damage.

**Table One: Perforated Metal**

IPA Number	Hole Diameter x Hole Spacing (inches)	Inline or Staggered	Percent Open Area
	0.033 x 0.050	Inline	28
	0.045 x 0.066	Inline	36
	0.062 x 3/32	Staggered	40
109*	0.094 x 5/32	Staggered	33
113*	1/8 x 3/16	Staggered	40
	5/32 x 3/16	Staggered	63
118*	3/16 x 1/4	Staggered	51
121*	1/4 x 3/8	Staggered	40
	5/16 x 7/16	Staggered	47
124*	3/8 x 1/2	Staggered	51
	7/16 x 19/32	Staggered	49
128*	1/2 x 11/16	Staggered	47
130*	5/8 x 13/16	Staggered	53
131*	3/4 x 1	Staggered	51
	1 x 1 3/8	Staggered	48

\*These are standards as they appear in the *Designers, Specifiers and Buyers Handbook for Perforated Metals* published by the Industrial Perforators Association (IPA).

As shown in Table One, perforated metal is available in inline or staggered geometries (Fig. 19). Generally, smaller diameter hole sizes are available in the inline pattern and larger hole sizes are of the staggered type. Hole size refers to the size of the hole punched in the metal. Hole spacing is the distance between the centers of two adjacent holes. For a given hole size, the greater the hole spacing, the lower the percentage open area of the perforated metal.

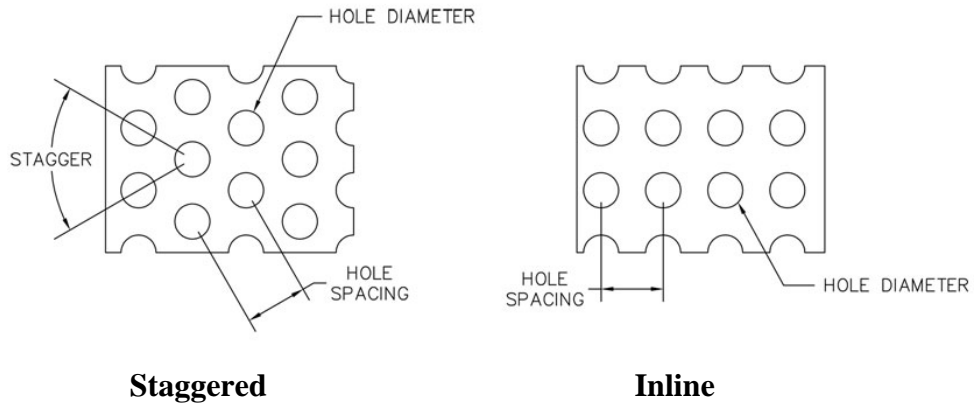

**Figure 19**

**Table Two: Mesh**

Mesh (Openings/In.)	Wire Diameter (In.)	Opening		Percent Open Area
		Inches	Micron	
10	0.032	0.068	727	56.3
16	0.018	0.045	1130	50.7
18	0.017	0.036	979	48.3
20	0.015	0.035	889.0	49.0
30	0.011	0.0223	566.4	44.8
40	0.009	0.0156	396.2	40.2
50	0.009	0.011	279	30.3
60	0.0065	0.0102	259.1	37.3
80	0.005	0.0075	190.5	36.0
100	0.0045	0.0055	139.7	30.3
120	0.0035	0.0048	123	30.1
150	0.0026	0.0041	103	37.2
170	0.0024	0.0035	79	35.1
200	0.0020	0.0030	76.2	33.6
250	0.0016	0.0024	61	36.0
300	0.0012	0.0021	54.2	29.7
325	0.0012	0.0019	47.7	30.0
400	0.0011	0.0014	35.6	36.0

**Table Three: Wedge Wire**

Opening	Micron	Percent Open Area
0.003"	75	
0.005"	127	7.7
0.010"	254	14.3
0.015"	381	20
0.020"	500	25
0.031"	775	34
0.034"	864	20
0.062"	1550	50
0.063"	1600	51
0.094"	2350	61
0.125"	3175	67
0.156"	3962	71

## **CHAPTER 6**

### ***Capacity***

The capacity ratio or open area ratio (OAR) of a strainer influences such operating characteristics as the length of time it can operate without cleaning and the created pressure loss. The OAR is the relationship between internal cross sectional area (flow area) of the pipe and the open flow area of the material which makes up the straining element. The nominal pipe size should be used to calculate OAR for threaded strainers.

A 100% OAR, or 1-to-1 ratio, would give an unrestricted flow area equal to that of the pipe while the element was clean. However, as clogging occurs flow would be inhibited. A 200% OAR, or 2-to-1 ratio would provide full flow, after the element became 50% clogged. However, larger OAR's would be appropriate for flow in which much debris is expected to be strained or where very viscous fluids are being handled.

When considering the OAR of a straining element, there are two accepted methods of analysis used by various specifying agencies and manufacturers. One method maintains "line of sight" reasoning and uses the multiple of the open areas for elements in series. In this method, a 60% open area material in series with a 40% open area material has a resultant combined open area of 24% (i.e. as in accordance with Military Standards). An alternative method allows the open area of the more restrictive element in series to be used. This alternative method is allowable because fluid does not always flow straight through the mesh in a "line of sight" flow path – it can actually flow sideways between the weaves of the mesh which reduces the restrictions. There is also typically some space between the mesh and the perforated plate for lateral flow.

This would be 40% for the example above (i.e. as in accordance with Underwriter Laboratories' Standards). The method used influences the estimated operating pressure drop, as well as design decisions such as sizing.

As an example, fuel oils are generally strained to a fine degree to protect small orifices in burner nozzles. This requires a fine woven mesh be used in series with a reinforcing perforated plate. Due to the fact that the perforated plate may have a 50% open area and the mesh 30%, the resultant combined open area will be only 15% based on the “line of sight” method. This, of course, would mean that to have an OAR of 250%, a high capacity, large bodied strainer is required.

This same strainer using only the perforated plate would have an OAR more than three times as great. So, it may be seen that in any given strainer, the OAR will change by using various perforations and/or meshes having different open areas. Thus, it is essential to specify not only the OAR desired, but the straining element opening size and the method for calculating OAR.

## **CHAPTER 7**

### ***Pressure Loss***

Because strainers are made with various dimensions and configurations, most reputable manufacturers have tested and published pressure drop results.

Most pump installations designed for reasonable velocities will permit approximately 2 psi pressure drop across the strainer. When a screen becomes clogged, the pressure drop will increase. This increase varies with the clogging pattern experienced and the type of strainer being used. While some manufacturers speculate as to the change in pressure drop at different percentages of clogging, it should be recognized that this type of testing is very difficult to relate to actual line performance. This is because of differences in strainer clogging characteristics — a 1/4” perforated basket two-thirds full of 1/2” stones will be less affected than a small amount of fine leaves on a large 100 mesh basket. If large amounts of solids are expected, use a strainer with a high net open area as discussed in Chapter 6.

As a strainer becomes clogged to the point where the OAR of the strainer approaches the pipe cross sectional area, the pressure drop across the strainer will increase very rapidly and unpredictably. It is at this point that it is recommended the strainer be cleaned. Otherwise, a large differential pressure will develop. The maximum differential pressure a strainer can withstand varies widely with strainer type, line size and materials used. Always consult the manufacturer for maximum differential pressure a straining element can withstand.

The maximum differential pressure the screen or basket can withstand before it fails is known as the burst pressure. Burst pressure can be difficult to calculate. It is dependent on many factors. These factors include the material of construction, the thickness of the material, the size and geometry of the straining element, and the percentage open area of the perforated metal used. In practice, it is advisable to never allow the pressure drop across the strainer to approach the burst pressure of the straining element.

From the foregoing discussion, it is obvious that periodic cleaning is essential in any strainer installation. Once the rate of clogging is established, a cleaning schedule can be developed. Pressure gauges on each side of the strainer can be utilized to determine when the strainer requires cleaning. Differential pressure switches can be set up to operate warning lights or alarms if so desired.

Some manufacturers have related their strainers' pressure drop to equivalent feet of pipe at various turbulent flow rates, and this can simplify the computation of head loss for an entire system. However, varying field conditions and fluid properties can affect the accuracy of general type pressure drop estimations. Further, operating viscous fluids under laminar flow conditions requires analysis different from that for fluids under turbulent conditions. Accordingly, the manufacturer should always be consulted for the most specific and accurate estimated pressure loss.

## **CHAPTER 8**

### ***Specifications and Manufacturer Testing***

The more information the customer is able to provide to the manufacturer when ordering strainers, the better the chance of obtaining a strainer which is appropriately suited for a particular job. It is for this reason that considerable space is devoted to the preparation of specifications.

### ***Specification***

To allow the manufacturer to make selection or recommendations for a particular strainer, as much as possible, the following information should be provided:

#### ***A. Physical Characteristics***

- 1 – Pipe size and schedule.
- 2 – Strainer type required.
- 3 – End connections.
- 4 – Material (body, screen, bolting, gaskets).
- 5 – Pressure rating (design/operating — including shock).
- 6 – Temperature rating (design, operating, minimum).
- 7 – Straining element opening size.
- 8 – Capacity:
  - (a) Net effective open area required.
  - (b) Method of net open area calculation.
- 9 – Special requirements (hinged cover, vent tapping, jacketed, etc.).
- 10 – Applicable specifications (military specifications, special nondestructive tests or other quality control requirements).
- 11 – For automatic self-cleaning strainers, specify the following:
  - (a) Voltage and frequency of power supply.
  - (b) Air supply pressure if available.
  - (c) Type of controls desired.
  - (d) Type of motor, switch and control panel enclosure required.

**B. Flow Data**

1 – Liquid:

- (a) Description of fluid.
- (b) Rate of flow – gallons per minute (gpm) or pounds per hour (lbs/hr).
- (c) Viscosity – SSU.
- (d) Specific gravity or density.
- (e) Temperature.
- (f) Concentration (if acid or other corrosive).

2 – Gas:

- (a) Description of Gas.
- (b) Rate of flow – standard cubic feet per minute (scfm) or actual cubic feet per minute (cfm).
- (c) Specific gravity.
- (d) Temperature and pressure.
- (e) Molecular weight.

3 – Steam:

- (a) Rate of flow-pounds per hour (lbs/hr).
- (b) Temperature.
- (c) Pressure.
- (d) Density.
- (e) State of flow.

**C. Solids to be Removed**

Specify the nature and relative size of the sediment. Parts per million (ppm) or percent by volume or cubic inches per hour or percent by weight can also be specified.

**D. Allowable Pressure Drop (psi):**

- 1 – Clean.
- 2 – 50% clogged.

NOTE: Operating pressure drop is a function of operating conditions, fluid characteristics and strainer geometry. Consequently, if specifying a strainer type and geometry, a desired pressure drop may not be obtainable if fluid parameters are fixed. The “trade-off” relationship between fluid conditions, strainer geometry and operating pressure drop establishes what compromises must be made.

If strainer is to be steam jacketed, the following information for the heat transfer fluid or steam must be given:

- (a) Type of fluid.
- (b) Rate of flow.
- (c) Temperature.
- (d) Pressure.
- (e) Type and size connections desired.
- (f) Material for jacket construction.
- (g) Whether strainer end flanges are oversized to match jacketed pipe.

## ***Available Types of Manufacturer Testing***

### ***A. Hydrostatic Test:***

Most common test – usually 1.3 (ASME Boiler and Pressure Vessel Code) or 1.5 (ASME B31 Code for Pressure Piping) times the design pressure to determine that a strainer will not leak at the design pressure.

### ***B. Radiographic Examination:***

This test determines if the casting or welded joint has any slag or sand inclusions, gas pockets or subsurface defects. This type of test is quite expensive and usually specified only for high pressure strainers.

### ***C. Magnetic Particle Examination:***

A reasonably low cost examination to reveal relatively shallow subsurface cracks, gas pockets, etc. Iron dust is sprinkled on the surface of the casting/weld and a magnetic force is induced electrically. This causes the dust to align over any defects and cracks, and shows their location and size. This examination can only be used on iron and steel.

### ***D. Dye Penetrant Examination:***

Equivalent to magnetic particle testing, except used mainly with nonmagnetic castings/welds to reveal surface defects, cracks, depressions, etc.

### ***E. Air Test:***

Either under water or with part covered with soap solution. This is a more stringent test for porosity and gasket leakage than hydrostatic, and leaks often are more obvious. This test is not often done, due to relative danger involved.

### ***F. Hydrostatic Burst Test:***

Sometimes done to establish manufacturer's maximum working pressure rating, or at the request of purchaser.

### ***G. Shock Test:***

This is usually a government requirement where strainers will remain operative or intact in the event of a near-proximity explosion. Test normally conducted on a machine where weighted hammer strikes plate on which strainer is mounted.

### ***H. Vibration Test:***

Normally a government requirement where strainers must withstand a vibration test which involves a number of frequencies. This usually simulates shipboard vibrations, earthquake, etc.

### ***I. Surge Test:***

A strainer is pressurized with water and a quick-opening valve on the outlet flange is quickly opened to determine that no damage is sustained by the basket. This is normally a military requirement.

***J. Helium Leak Test:***

Helium leak test is a very stringent test where the strainer is pressurized with helium and leaks are checked with sensitive instruments. A maximum leak rate is usually specified. Used mainly for nuclear plants for radioactive water piping.

***K. Ferroxy Test:***

This test detects free iron in stainless steel strainers where the iron would contaminate the product.

NOTE: Many tests by their very nature can be more or less stringent. Acceptance standards should be included in any inquiry calling for such tests. Naturally, the more stringent the test requirements, the more costly the ultimate strainer becomes.

**CHAPTER 9**

***Shock: Hydraulic and Thermal***

No attempt will be made here to go into the highly technical field of hydraulic shock, and it is covered briefly to point out that even if your system can produce only a specific head, if the possibility of shock is present, tremendous overpressures may result.

Any liquid being transmitted in a pipeline possesses a certain amount of energy (weight multiplied by velocity). A rapid change in velocity results in a momentary shock wave. In the case of a quick-closing valve, the energy of the flowing fluid must be dispersed in some way, and the resulting shock, or “water hammer”, is clearly audible. A pressure wave, in some cases, travels at over 3 000 ft/s and traverses the pipeline in one direction, then the other, losing energy as it travels, until it is dissipated. A theoretical value of 54 psi for each foot per second of velocity that is stopped by the valve may be used. A 12 ft/s velocity could produce a shock wave having a peak of 648 psi; therefore, consideration should be given to the shock and non-shock rating of the strainer.

Commonly known is the phenomenon of pouring hot tea into a glass and watching the glass crack. This is an example of thermal shock. Rapid changes of temperature in piping systems can have the same effect. In selecting strainers, consideration must be given to this possibility.

In improperly steam trapped lines, condensate can collect in low points and subsequently become a slug of water traveling at high velocity down the line. Almost all strainers cause a change in direction of flow due to their configuration. The change in direction coupled with the water traveling at high velocity can result in damage or failure of the strainer. In considering this situation, it is important to remember that steam velocities of 70 to 350 ft/s are quite common.

## **CHAPTER 10**

### ***Conclusion***

Strainers are no longer confined to a simple cast body with a wire mesh screen, but are a technical, highly refined, carefully designed piece of equipment.

Sometimes they operate at 1 500 °F and 10 000 psig or at cryogenic temperatures. They are modified with steam jackets, cover lifting davits, magnets, motorized cleaning devices and automatic vent valves. They are supplied with screwed, flanged, socket weld, butt weld, ring type joint, and silver brazing end connections.

Accordingly, the implementation of a strainer needs to be well thought out and engineered. While it is good practice to use a strainer to protect downstream equipment, it is very important to carefully consider the options available. Choosing the correct strainer can save money not only by protecting equipment, but also by keeping operations and maintenance costs at a minimum.

This guide for the selection, installation and maintenance of pipeline strainers has been created by the Fluid Controls Institute, Inc., Pipeline Strainer Section, and represents the collective knowledge and experience of its members:

Armstrong International, Inc.  
The Mack Iron Works Co.  
Spence Engineering  
Spirax Sarco Inc.  
SSI Fabricated  
Sure Flow Equipment Inc.

## List of Figures

- Fig. 1A Y strainer, cast
- Fig. 1B Tee type basket strainer
- Fig. 1C Basket type strainer, cast
- Fig. 1D Basket type strainer, quick open cover
- Fig. 2 Self-cleaning Y strainer fitted with a blowdown valve
- Fig. 3 Tee type basket strainer, right angle flow
- Fig. 4 Basket strainer with blowdown assembly
- Fig. 5 High pressure fabricated basket strainer
- Fig. 6 Ball type duplex basket strainer, cast
- Fig. 7 By-pass twin basket straining assembly with individual control valves
- Fig. 8A Temporary strainer, cone
- Fig. 8B Temporary strainer, truncated cone
- Fig. 8C Temporary strainer, flat plate
- Fig. 9 Wash down strainer
- Fig. 10 Automatic self-cleaning strainer
- Fig. 11 Plate or expanded cross-section strainer
- Fig. 12 Rotary scraper strainer
- Fig. 13A Structurally stiffened tee type basket straining element
- Fig. 13B Structurally stiffened wire cone temporary strainer
- Fig. 14 Magnetic screen assembly
- Fig. 15 Offset basket strainer
- Fig. 16 Reducing basket strainer
- Fig. 17 Strainer housing equipped with steam jacket
- Fig. 18 Example of a quick-opening cover
- Fig. 19 Perforated metal geometry